



Bulletin MSG11-5715-666/UK

Operation Manual Series DFplus Pilot Operated

Design > 30



Proportional Directional Control Valve

Parker Hannifin
Manufacturing Germany GmbH & Co. KG
Industrial Systems Division Europe
Gutenbergstr. 38
41564 Kaarst, Germany
E-mail: isde.kaarst.support@support.parker.com
Copyright © 2022, Parker Hannifin Corp.

**WARNING — USER RESPONSIBILITY**

FAILURE OR IMPROPER SELECTION OR IMPROPER USE OF THE PRODUCTS DESCRIBED HEREIN OR RELATED ITEMS CAN CAUSE DEATH, PERSONAL INJURY AND PROPERTY DAMAGE.

This document and other information from Parker-Hannifin Corporation, its subsidiaries and authorized distributors provide product or system options for further investigation by users having technical expertise.

The user, through its own analysis and testing, is solely responsible for making the final selection of the system and components and assuring that all performance, endurance, maintenance, safety and warning requirements of the application are met. The user must analyze all aspects of the application, follow applicable industry standards, and follow the information concerning the product in the current product catalog and in any other materials provided from Parker or its subsidiaries or authorized distributors.

To the extent that Parker or its subsidiaries or authorized distributors provide component or system options based upon data or specifications provided by the user, the user is responsible for determining that such data and specifications are suitable and sufficient for all applications and reasonably foreseeable uses of the components or systems.

Contents	Page
1. Introduction	4
Ordering Code	4
Name Plate	5
Characteristics of Valve Driver	5
Block Diagram of Integral Electronics	5
Specifications	6
2. Safety Instructions	7
Symbols	7
Marking, Name Plates	7
Work at the Valve	7
3. Important Details	7
Intended Usage	7
Common Instructions	7
Liability	7
Storage	7
4. Mounting / Installation	8
Scope of Supply	8
Mounting	8
Operation Limits	8
Pressure Fluids	8
Electrical Connection	9
Electrical Interfacing	10
5. Operation Instructions	12
Preferred Hydraulic Initial State	12
Solenoid Current Monitoring	13
ProPxD Parametering Software	13
Air Bleeding of Hydraulic System	18
Filter	18
Flushing	18
6. Trouble Shooting	19
7. Accessories / Spare Parts	19
Accessories	19
Spare Parts	19

1. Introduction

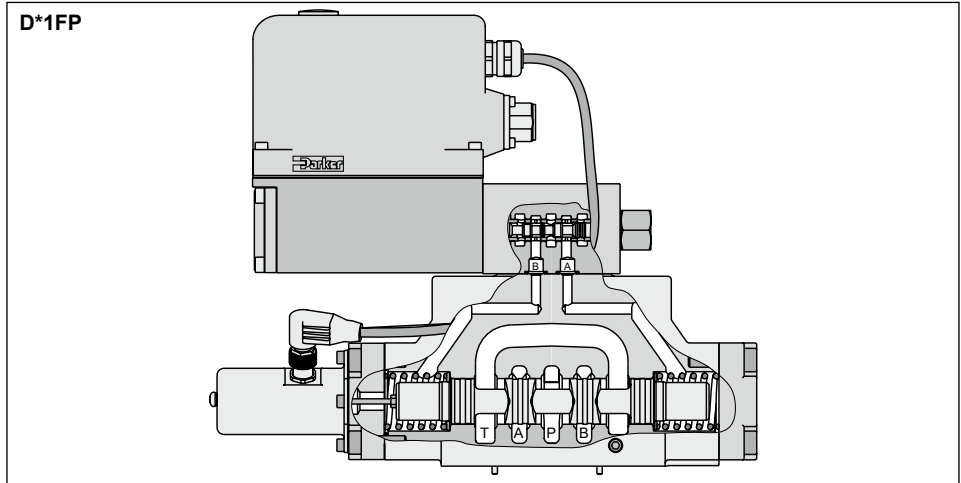

Ordering Code

D		1	F	P									
Direct control valve	Size				Function <small>(see catalogue)</small>	Flow <small>(see catalogue)</small>	Spool position on power down	Pilot connection <small>(see catalogue)</small>	Seal	Command signal	Electronic option	Valve option	Design series

Code	Size
3	NG10 / CETOP 05
4	NG16 / CETOP 07
8	NG25 / CETOP 08
9	NG25 / CETOP 08
11	NG32 / CETOP 10

Code	Spool position on power down
A ¹⁾	
B ¹⁾	
C ²⁾	

Code	Valve option
0	Standard for spool B, E, R
L	Hybrid valve 24V normally closed for spool code Z

Code	Electronic option
0	6 + PE
5	11 + PE
7	6 + PE w. Enable

Code	Signal	Function
B	± 10 V	0...+10 V -> P-B
E	± 20 mA	0...+20 mA -> P-B
K	± 10 V	0...+10 V -> P-A
S	4...20 mA	12...20 mA -> P-A

Code	Seal
N	NBR
V	FPM
H	for HFC fluids

¹⁾ Approx. 10 % opening, only zero lapped spools.

²⁾ For overlapped spools.

Operation Manual

Prop. Directional Control Valve Series DFplus Pilot Operated

Name Plate

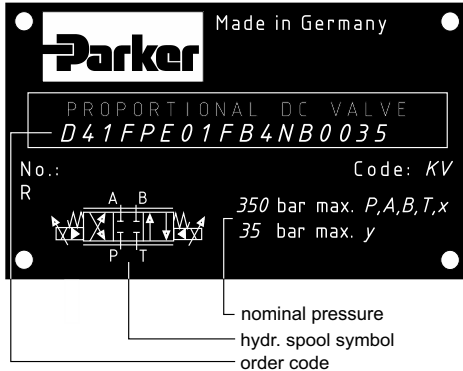

Parker D*1FP proportional directional control valves have an integral electronic. Different flow sizes, power-down positions as well as command signal options are available to achieve an optimal adaption for different applications.

Characteristics of Valve Driver

The described integral electronic driver combines all necessary functions for the optimal operation of the valve. Thanks to its excellent dynamic the valve is usable within closed loop control applications. The most important features are:

- high dynamic actuator principle with special designed electronic driver
- closed loop controlled pilot valve and main spool
- constant current actuator control with overcurrent shutoff
- excellent properties for response sensitivity and temperature drift
- differential input stage with various command signal options
- diagnostic output for spool stroke/overcurrent state



Block Diagram of Integral Electronics

Code 0 (6+PE)

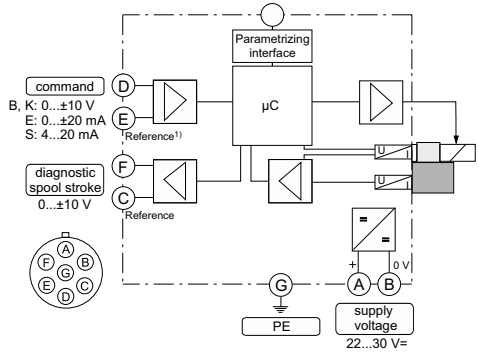

Code 5 (11+PE)

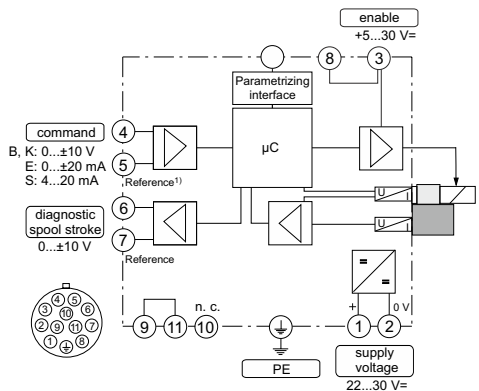

Code 7 (6+PE with enable)

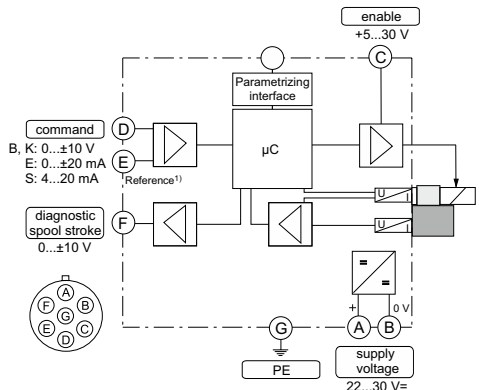

¹⁾ Do not connect with supply voltage zero.

Technical Data

General				
Design	Servo proportional directional control valve, pilot operated			
Actuation	VCD [®] -actuator			
Size	NG10 (CETOP 05)	NG16 (CETOP 07)	NG25 (CETOP 08)	NG32 (CETOP 10)
	D31	D41	D81 / D91	D111
Mounting Interface	DIN 24340 / ISO 4401 / CETOP RP121 / NFPA			
Mounting position	unrestricted			
Ambient temperature	[°C] -20...+50			
MTTF _p value	[years] 50			
Weight	[kg]			
	11.3	14.2	23.5	64.5
Vibration resistance	[g]			
	10 Sinus 5...2000 Hz acc. IEC 68-2-6			
	10 (RMS) Random noise 20...2000 Hz acc. IEC 68-2-36 15 Shock acc. IEC 68-2-27			
Hydraulic				
Max. operating pressure	[bar]	Internal pilot drain P, A, B, X 350; T, Y 35 External pilot drain P, A, B, T, X 350; Y 35		
Fluid	Hydraulic oil according to DIN 51524 ... 535, other on request			
Fluid temperature	[°C]	-20...+60 (NBR: -25...+60)		
Viscosity				
	permitted	[cSt]/[mm ² /s]	20...400	
recommended	[cSt]/[mm ² /s]	30...80		
Filtration	ISO 4406; 18/16/13			
Electrical				
Duty ratio	[%]	100		
Protection class	IP65 in accordance with EN 60529 (with correctly mounted plug-in connector)			
Supply voltage / ripple	[V]	22...30, ripple < 5 % eff., surge free		
Current consumption max.	[A]	3.5		
Pre-fusing	[A]	4.0 A medium lag		
Input signal	Code K (B) voltage	[V]	+10...0...-10, ripple < 0.01 % eff., surge free, 0...+10 V P→A (P→B)	
	Impedance	[kOhm]	100	
Code E current	Impedance	[mA]	+20...0...-20, ripple < 0.01 % eff., surge free, 0...+20 mA P→B	
	Impedance	[Ohm]	<250	
Code S current	Impedance	[mA]	4...12...20, ripple < 0.01 % eff., surge free, 12...20 mA P→A	
	Impedance	[Ohm]	<250	
< 3.6 mA = enable off, > 3.8 mA = enable on acc. NAMUR NE43				
Input Capacitance typ.	[nF]	1		
Differential input max.	Code 0	[V]	30 for terminal D and E against PE (terminal G) 11 for terminal D and E against 0V (terminal B)	
	Code 5	[V]	30 for terminal 4 and 5 against PE (terminal ↓) 11 for terminal 4 and 5 against 0V (terminal 2)	
	Code 7	[V]	30 for terminal D and E against PE (terminal G)	
	Code 5/7	[V]	5...30, Ri = > 8 kOhm	
Diagnostic signal	[V]	+10...0...-10 / +12.5 V, rated max. 5 mA		
EMC	EN 61000-6-2, EN 61000-6-4			
Electrical connection	Code 0/7	6 + PE acc. EN 175201-804		
	Code 5	11 + PE acc. EN 175201-804		
Wiring min.	Code 0/7	[mm ²]	7 x 1.0 (AWG16) overall braid shield	
	Code 5	[mm ²]	8 x 1.0 (AWG16) overall braid shield	
Wiring length max.	[m]	50		

2. Safety Instructions

Please read the operation manual before installation, startup, service, repair or stocking! Paying no attention may result in damaging the valve or incorporated system parts.

Symbols

This manual uses symbols which have to be followed accordingly:



Instructions with regard to the warranty



Instructions with regard to possible damaging of the valve or linked system components



Helpful additional instructions

Marking, Name Plates

Instructions applied on the valve, i.e. wiring diagrams and name plates, must be observed and maintained legibly.

Work at the Valve

Workings in the area of installation, commissioning, maintenance and repair of the valve may only be allowed by qualified personnel. This means persons which have, because of education, experience and instruction, sufficient knowledge on relevant directives and approved technical rules.

3. Important Details

Intended Usage

This operation manual is valid for proportional directional control valves DFplus pilot operated series. Any different or beyond it usage is deemed to be as not intended. The manufacturer is not liable for warranty claims resulting from this.

Common Instructions

We reserve the right for technical modifications of the described product. Illustrations and drawings within this manual are simplified representations. Due to further development, improvement and modification of the product the illustrations might not match precisely with the described valve. The technical specifications and dimensions are not binding. No claim may result out of it. Copyrights are reserved.

Liability

The manufacturer does not assume liability for damage due to the following failures:

- incorrect mounting / installation
- improper handling
- lack of maintenance
- operation outside the specifications



Do not disassemble the valve! In case of suspicion for a defect please contact Parker.

Storage

In case of temporary storage the valve must be protected against contamination, atmospheric exposure and mechanical damages. Each valve has been factory tested with hydraulic oil, resulting in protection of the core parts against corrosion. Yet this protection is only ensured under the following conditions:



Outdoor storage or within sea and tropical climate will lead to corrosion and might disable the valve!

Storage period	Storage requirements
12 months	constant humidity < 60 % as well as constant temperature < 25 °C
6 months	varying humidity as well as varying temperature < 35 °C

4. Mounting / Installation

Scope of Supply

Please check immediately after receiving the valve, if the content is matching with the specified scope of supply. The delivery includes:

- valve
- operation manual

The central connector assembly has to be ordered separately and is not included in the delivery.

 Please check the delivery immediately after receiving the shipment for apparent damages due to shipping. Report shipment losses at once to the carrier, the insurance company and the supplier!

Mounting

- Compare valve type (located on the name plate) with part list resp. circuit diagram.
- Unrestricted mounting position.
- Verify the mounting surface for the valve. Unevenness of 0.01 mm/100 mm, surface finish of 6.3 µm are tolerable values.

 Keep clean valve mounting surface and work environment!

- Remove protection plate from the valve mounting surface
- Check the proper position of the valve ports and the O-rings.
- Mounting bolts:
D31FP: 4 pcs. M6x40
D41FP: 2 pcs. M6x55, 4 pcs. M10x60
D81/91FP: 6 pcs. M12x75
D111FP: 6 pcs. M20x90
use property class 12.9, ISO 4762

 Parker offers bolt kits:

D31FP: BK385, D41FP: BK320, D81/91FP: BK360, D111FP: BK 386

- Tighten the bolts crisscross with the following torque values:
D31FP: 13.2 Nm, D41FP: 13.2/63 Nm,
D81/91FP: 108 Nm, D111FP: 517 Nm



Insufficient condition of the valve mounting surface might create malfunction! Incorrect mounting resp. bolt torque may result in abrupt leakage of pressure fluid on the valve ports.

Operation Limits

The valve may be operated within the determined limits only. Please refer to the "technical data" section as well as to the "characteristic curves" in the catalog.



Follow the environmental conditions! Unallowable temperatures, shock load, aggressive chemicals exposure, radiation exposure, illegal electromagnetic emissions may result in operating trouble and may lead to failure! Follow the operating limits listed in the "specifications" table!

Pressure Fluids

The following rules apply for the operation with various pressure fluids:



This information serves for orientation and does not substitute user tests among the particular operating conditions. Particularly no liability for media compatibility may be derived out of it.

Mineral oil: usable without restriction.

HFC: choose the right seal option.

For operation with the following pressure fluids please consult Parker:

HFA	oil-in-water emulsion
HFB	water-in-oil emulsion
HFD	anhydrous fluids (Phosphor-Ester)



For detailed information concerning pressure fluids note VDMA-document 24317 as well as DIN 51524 & 51502.

Special gaskets may be available depending on the utilized fluid.

In case of insecurity please consult Parker.

Operation Manual

Electrical Connection

The electrical connection of the valve takes place by one common cable, which is coupled to the integrated electronic driver by a central connector assembly.

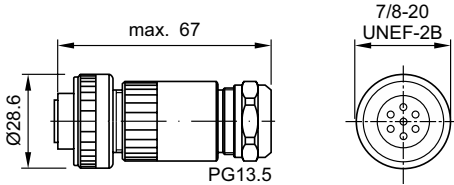

The connection Code 0 as well as Code 7 requires a 6 + PE female connector EN 175201-804.

☞ The female connector has to be ordered separately under article nr. 5004072.

⚠ A female connector with metal housing is required! Plastic made models may create function problems due to insufficient EMC-characteristics.

The connecting cable has to comply to the following specification:

Cable type	control cable, flexible, 7 conductors, overall braid shield
Cross section	min. AWG16
Outer dimension	8...12 mm
Cable length	max. 50 m

☞ For cable lengths > 50 m consult Parker.

The connection cable is coupled to the female connector by solder joints.

Skinning lengths for the connecting cable:

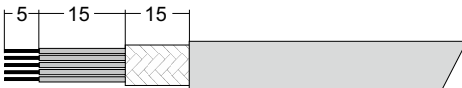

The connection Code 5 requires a 11 + PE female connector EN 175201-804.

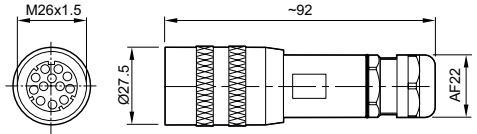

☞ The female connector has to be ordered separately under article nr. 5004711.

⚠ A female connector with metal housing is required! Plastic made models may create function problems due to insufficient EMC-characteristics.

The connecting cable has to comply to the following specification:

Cable type	control cable, flexible, 8 conductors, overall braid shield
Cross section	min. AWG16
Outer dimension	12...15 mm
Cable length	max. 50 m

☞ For cable lengths > 50 m consult Parker.

The connection cable is coupled to the female connector by crimp contacts.

Skinning lengths for the connecting cable:



☞ For the workmanlike termination of the crimp contacts the tool # 932 507-001 – supplier: Hirschmann – is required.

⚠ Do not disconnect cable socket under tension!

The shielding has to be assembled according the outline below:

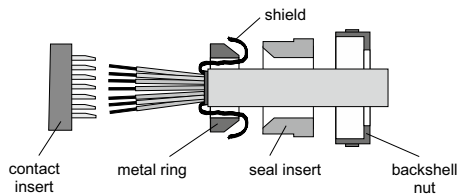

The backshell nut of the cable gland has to be tightened with a suitable tool. The target value for the tightening torque is 4 Nm. Tighten the cap nut with a torque of approx. 5 Nm after attaching the female connector on the socket outlet.

 Incomplete tightening of backshell nut resp. cap nut may result in automatic release of the connection as well as degradation of the water tightness.

Follow the "instructions for use" for installation of female connectors made by other kind of brands!

 The cable connection to the female connector has to take place by qualified personnel! A short between individual conductors resp. to the connector housing, bad soldering as well as improper shield connection may result in malfunction and breakdown of the valve.

 The mounting surface of the valve has to be carefully tied to the earth grounded machine frame. The earth ground wire from the valve connecting cable as well as the cable shield have to be tied to the protective earth terminal within the control unit. It is necessary to use a low ohmic potential connection between control unit and machine frame to prevent earth loops (cross section AWG 6).

Electrical Interfacing

Supply Voltage

The supply voltage for the valve has to cover the range of 22...30 V. The residual ripple may not exceed 5% eff.

 The applied power supply must comply to the relevant regulations (DIN EN 61558) and must carry a CE-mark. The operating voltage for the valve must be free of inductive surges. Do not exceed the max. value of 30V! Non-observance of this rule may result in permanent damaging of the valve.

 The increased inrush current of the valve should be considered when selecting the power supply. A stabilized power supply with overcurrent limiting feature should not be used. Due to the inrush current of the valve the current limit circuit may respond prematurely and create problems during energizing of the supply voltage.

 The operation of the valve is blocked if the supply voltage polarity is interchanged.

 Each valve requires a separate pre-fuse of 4 Amp time lag. Non-observance of this instruction may create irreparable damage of valve resp. incorporated system parts.

Wiring

Code 0, 6 + PE acc. EN 175201-804

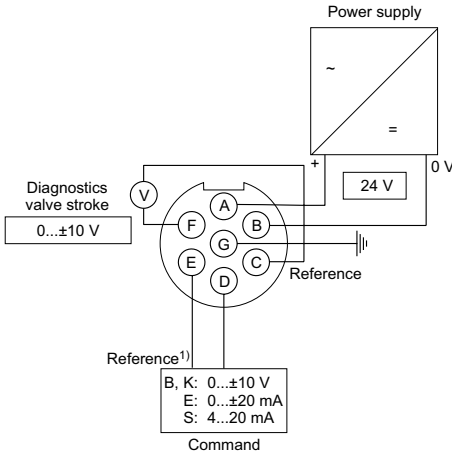

Code 5, 11 + PE acc. EN 175201-804

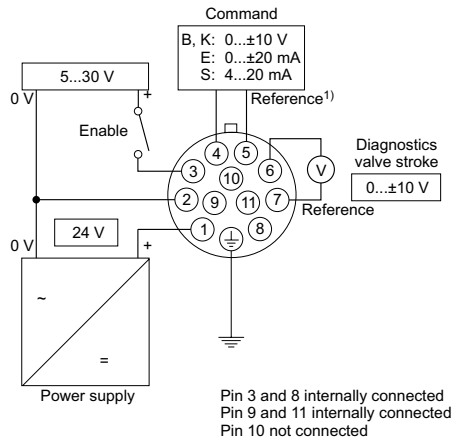

Code 7, 6 + PE acc. EN 175201-804 + enable

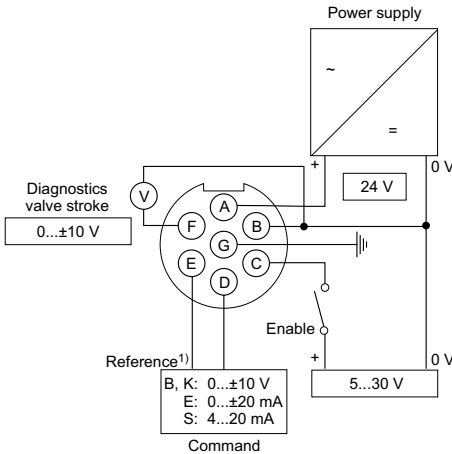

¹⁾ Do not connect with supply voltage zero.

Enable input (only for Code 5 / 11+PE as well as Code 7 / 6+PE)

A signal voltage enables the actuator drive of the valve. Continuous operation of the valve requires a permanent voltage 5...30 V (i.e. the supply voltage). In case of disabling the signal the valve will reach its power down position spring-actuated independently from the command signal value.

 The enable function represents no safety arrangement against unwanted valve operation in terms of rules for accident prevention!

Command signal input

The spool stroke behaves proportional to the command signal amplitude.

 The command input signal needs to be filtered as well as free of inductive surges and modulations. Due to the sensitivity of the valve a high signal quality is recommended, this will prevent malfunction.

 Incorrect signal amplitude levels may disturb the functionality and can damage the valve.

 The option 4...20 mA uses the “3.6 mA” condition as breakdown-information. This means the presence of an evaluable failure information if the input signal line is interrupted. In this case the actuator drive will be switched off. The drive will switch on when the input signal reaches a value of 3.8 mA, it switches off when the command falls below 3.6 mA. This determination follows the NAMUR-specification NE43.

NAMUR is an association of users of process control technology.

Diagnostics output

A diagnostics signal is available. Its voltage represents the operating condition of the valve.

 The output may drive a load of max. 5 mA. Exceeding of this limit leads to malfunction.

Code command signal	Command signal	Function	VCD actuator	Diagnostic signal
B	0...+10 V		on	0...-10 V
	0...-10 V		on	0...+10 V
	Overload		off	ca. 12.5 V
E	0...+20 mA		on	0...-10 V
	0...-20 mA		on	0...+10 V
	Overload		off	ca. 12.5 V
K	0...+10 V		on	0...+10 V
	0...-10 V		on	0...-10 V
	Overload		off	ca. 12.5 V
S	4...12 mA		on	0...-10 V
	12...20 mA		on	0...+10 V
	0...3,6 mA		off	Cable break, ca. 12.5 V
	Overload		off	ca. 12.5 V

5. Operating Instructions

Preferred Hydraulic Initial State

 For valves with zero lap spools, distinction must be made between hydraulic neutral position and power-down position. Neutral position is taken at neutral input signal, corresponding to zero position of the hydraulic symbol. When the valve is switched off – no supply voltage, no enable, current signal (code S) < 3,8 mA – zero lap valves take the power down position (approx. 10 % opening) according to the ordering code. For valves with overlap spools, neutral position and power down position are the same (zero position).

 Supply pressure must be ensured before valve is energized.

¹⁾ Diagnostic signal 12,5 V in error case. Spool moves in a defined position, please see ordering code „spool position at power down“.

Solenoid Current Monitoring

If the actuator current time interval exceeds 10 seconds, the actuator is switched off to prevent overheating. For normal operating conditions this state will not be reached, but it may occur with a contaminated sluggish valve.

 In this case the reason for the contamination should be repaired (hydraulic fluid exchange, filtration review, valve flushing).

The overcurrent shutoff condition may be reset by the actions below:

Code 0: Temporary disconnection of the supply voltage.

Code 5: Temporary disconnection of the enable signal.

Code 7: Temporary disconnection of the enable signal.

 The shutoff of the VCD actuator due to overload will be signaled via the diagnostics output.

PropxD parameterizing software

The PropxD software permits comfortable parameter setting for the module electronic. Via the clearly arranged entry mask the parameters can be noticed and modified. Storage of complete parameter sets is possible as well as printout or record as a text file for further documentation.

The PC software can be downloaded free of charge at www.parker.com/isde - see page "Support" or directly at www.parker.com/propxd.

Please check periodical for updates.

Hardware requirements

- PC with operating system from Windows® XP upwards
- Interface RS232C
- display resolution min. 800 x 600
- connection cable between PC and electronic module
- storage requirement approx. 40 MB

 If your PC has no serial interface according to RS232 standard you require in addition an USB-RS232 adapter.

Cable Specification

 Attention! The valve electronic provides no USB interface, but can only be parameterized via an RS232C connection. Therefore the usage of USB standard cables is not allowed and may result in damaging of valve resp. P C .

Parametrizing

Ordering code: 40982923

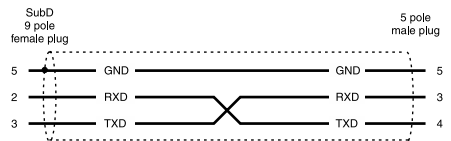
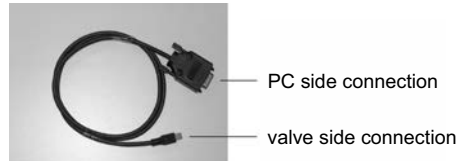

Parametering interface

Plug for parametering interface 

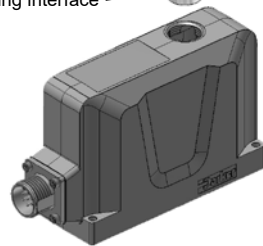

 The cover plug has to be re-installed after completion of the parametrizing work.

Program installation

Please check before installation if the above hardware requirements are met. If your PC has already stored an older version of the "ProPxD" program, it has to be deinstalled by using the Windows® - system control feature.

Program installation sequence:

- terminate the execution of other programs
- execute the file "setup.exe"
- follow the instructions on the screen

Answer the question, if an older version should be overwritten, with "ok". During the installation you may change destination drive resp. installation path, if needed.

Please answer "ok" if at the end of the installation the program reports any system information. After successful installation the desktop display shows the ProPxD icon for starting the program.

Software Operating

Brief instruction for first startup:

- Connect the valve electronic to the supply voltage.
- Connect the valve electronic to a PC via the parametrizing cable.
- Start the operating program.
- After displaying the program resp. data base version a program window opens and the connected valve will be automatically identified (possibly a manual identification via the button "Receive all" is necessary).
- Select the desired version via the menu "Options/Optionen" with the menu item "Language/Sprache".
- The valve specific default parameters are already available within the parameter table.
- Parameter changes are possible via mouse or the arrow buttons on the bottom left within the program screen, also the parameter values may be edited via the keyboard.
- Modified parameters will be stored via the "Enter" key or via the button "Update list".
- Parameters have to be nonvolatile stored on the valve via the button "save parameter".
- The chosen parameters may be optionally stored on the PC via the "File"-menu with the menu item "Save as", data retrieving is always possible via the function "Load file"

Extended functions:

The user software is shared into 2 parameter ranges:

- basic mode
- expert mode

For normal startup the basic mode is sufficient. It permits the setting of all application specific parameters to match the valve function with the task setting.

In case of special applications the valve parameters may be adapted via the expert mode. The operating mode may be selected from the "Options"- menu and remains after terminating and re-start of the program.



Changing of expert parameters is only permitted for qualified personnel. Incorrect settings may lead to malfunction! In case of parameter changes shut the drive down!

To prevent an unauthorized access for the expert mode, a pass word is requested. The name is "parker" and cannot be changed. Thus additionally to the button "Default" for loading of the default parameters, the button "Send parameter" appears in the "Expert"-operating mode. This button transmits only the setting of one single parameter to the connected valve. Thus a quick tuning of single parameters is permitted during the setup.



A horizontal bar graph readout between the communication buttons shows the data transfer state.



Because the ProPxD program has also without connection to the valve functionality, a manual pre-selection of the parameters is possible. After selection of the valve type via the menu "Options" the parameters may be set and stored for later transmission.

Note the design series while selection of the valve!

The "File" menu provides the functions "Printer setup", "Print preview" and "Print". The print preview includes the option for parameter set storage as text file (format.txt) prior to further processing. The "Options" menu provides also the selection of the RS232 interface port via the menu item "Port". Via the menu item "Load file" previously stored parameter sets may be loaded.

LED flashing signals of the valve electronics

enable valve OK: approx. 0.5 Hz (slowly, green)
 disable valve OK: approx. 1 Hz (fast, green)
 valve error: approx. 10 Hz (very fast, green)

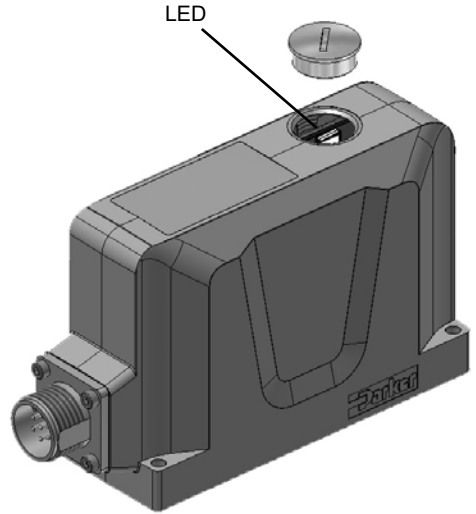

Closer information can be can be displayed via the ProPxD Parametrier software.

Error code

Error code (additive)	Error description
0	no errors
1	over current
2	cable break command signal
4	cable break feedback signal
8	undervoltage error
16	bus communication error
32	hardware failure

Adjustment parameters

The available parameters may be divided into multiple groups and are characterized by different letters:

- S-parameters
- P-parameters
- J-parameters

Parameter overview for basic mode

Parameter	Description	Unit	Parameter Range		Default Setting	Comment
			from	up to		
P1	Zero adjust	%	-90.0	90	0.0	
P3	MAX channel A	%	50.0	100.0	100.0	
P4	MAX channel B	%	50.0	100.0	100.0	
P7	MIN channel A	%	0.0	50.0	0.0	
P8	MIN channel B	%	0.0	50.0	0.0	
E17	option command	-	1 = ± 10 V		1 = ± 10 V	only displayed, not adjustable
			2 = ± 20 mA			
			3 = 4-20 mA			
E19	cable break detection command	-	0	0 (± 10 V / ± 20 mA)	0/1	code S0 only ¹⁾
				1 (4...20 mA)		
E25	MIN operating threshold	0.01 %	50	200	100	

Individual Description of Basic Parameters

P1	Adjustment of zero position shifting (offset). To compensate for unbalances.
P3 MAX +	Adjustment of maximum signal span for positive output signal. To match the command signal span to the valve operating range.
P4 MAX -	Adjustment of maximum signal span for negative output signal. To match the command signal span to the valve operating range.
P7 MIN +	Adjustment of stroke step for valve side A at min. operating threshold. To compensate for the overlap of the valve spool.
P8 MIN -	Adjustment of stroke step for valve side B at min. operating threshold. To compensate for the overlap of the valve spool.
E17 option command	Adjustment of the command signal option. To match the command signal input to the input signal mode.
E19 cable break detection command	Adjustment of the operating mode for the command cable break detection. To turn on resp. off of the cable break detection of the command signal at a selected command signal option of 4...20 mA.
E25 operating threshold	Adjustment of the MIN operating threshold. To match the response sensitivity for the MIN-stroke step.

 ¹⁾ Parker strongly advises not to turn off the cable break detection. In case of a deactivation, the cable break detection function of the machine must be essentially known.

Overview for additional expert mode parameter

Parameter	Description	Unit	Parameter Range		Default Setting	Comment
			from	up to		
J8	Min supply voltage supervision	V	17	28	18	
J9	Relay time out off range min supply voltage	ms	0	3200	1000	
J12	Errorhandling		0 = no fault acknowledgment necessary; 255 = fault acknowledgment necessary; 768 = no fault acknowledgment + Fault report about diagnosis; 1023 = fault acknowledgment + Fault report about diagnosis		768	

Individual description of additional expert parameters

J8 Min supply voltage supervision	Adjustment of the minimal supply voltage: Below this supply voltage the valve switches off with an error message.
J9 Relay time out off range min supply voltage	Adjustment of the runtime monitoring: The supply voltage must be at least constantly before the valve is ready for operation.
J12 Errorhandling	Adjustment of the fault response or report: 0 = no fault acknowledgment necessary 255 = fault acknowledgment necessary 768 = no fault acknowledgment + Fault report about diagnosis 1023 = fault acknowledgment + Fault report about diagnosis

Error messages

Malfunctions when using the ProPxD software program will be indicated via appropriate failure messages.

Failure messages and corrective actions:

Failure message	Description/corrective action
The Com Port is not available!	Terminate the other program, or quit the message and select another RS-232 port via the menu "Options > Port". Afterwards reconnect the parametrizing cable.
Unable to open COM port	Com port is not available. Quit the message and select another RS-232 port via the menu "Options > Port". Afterwards reconnect the parametrizing cable.
There is no module/valve connected or the communication is disturbed! Please check also the interface!	No data exchange possible. Either the electronic has been removed, the port is mismatched, or the connection will be disturbed by strong electrical fields. Check if the Com port is set for "9600, 8, 1. none, none" via the menu "Options > Port".
Wrong password	Retype the password, notice the exact spelling (case sensitivity).
Wrong input	An invalid character or a value outside the permitted range has been used at parameter entry.
Keep the entered parameters?	During parameter loading from the electronics memory the preset parameters from the left hand screen display may be rejected or maintained.
The chosen module/valve isn't the same as the connected hardware. Attention! Unsaved parameters will be lost.	In principle, parameters dedicated to a type which deviates from the connected valve may be edited. However, for data transmitting the correct valve has to be connected. If parameters will be loaded from a valve which deviates from the selected one, the parameters from the left hand side screen display of the program will be overwritten.
The chosen hardware isn't the same as the connected module/valve.	The wrong valve type has been selected from the database, afterwards the function "send all" has been executed.
Attention! Factory settings will be changed! Transmit anyhow?	Default parameters has been read out from the database instead from the valve via the function "receive all".
file name.pxd already exists. Do you want to replace the file?	The file name already exists within the indicated directory. Select another name, another directory or overwrite the existing file with "OK".

Air Bleeding of Hydraulic System

During initial startup, after an oil change as well as after the opening of lines or valves the hydraulic system must be air bled.

Filter

The function and lifetime of the valve are strongly affected by the cleanliness of the fluid.

purity level class of 18/16/13 acc. ISO4406 is required.

Flushing

It is recommended to flush the pipelines by short circuiting the pressure and return lines. This prevents the installation dirt from entering the valve.

